

USER MANUAL

Typ 9186-VX1XX

**DIGITAL INDICATOR
FOR LOAD CELL INPUT**

INDEX

GENERAL INFORMATION

Package contents	3
General safety considerations	3
Symbols identification	3
Maintenance	4
Conformity declaration	5
Device description	6
Dimensions and mounting	6
Display and keyboard	7
Installing and connecting recommendations	7
Connections	8
Load cell input (mV)	8
Remote TARE function	9
Relays output	9

INPUT CONFIGURATION

Configuration menu	10
Input configuration	10

DISPLAY CONFIGURATION

Display programming	12
Display scaling	12
mV input	13

SETPOINTS CONFIGURATION

Setpoints configuration	14
-------------------------------	----

AVAILABLE KEYBOARD FUNCTIONS

TARE, MAX/MIN and RESET functions	15
Direct access to setpoints value	15
Return to default configuration	16
Access to lock-out configuration menu	16

CONFIGURATION LOCK-OUT

Lock-out menu	17
---------------------	----

OUTPUT OPTION

Description	19
Function modes description	19
HI/LO mode activation	19
Time delay	19
Asymmetrical hysteresis	19
Installation	20

DESK VERSION OPTION 9186-V31XX

Connectors location and description	21
---	----

SPECIFICATIONS

Technical specifications	22
--------------------------------	----

GENERAL INFORMATION

This manual does not constitute a contract or a commitment on the part of burster präzisionsmesstechnik gmbh & co kg. All information contained in this document is subject to change without prior notice.

MANUAL VALID FOR INSTRUMENTS WITH C2.00 SOFT VERSION OR HIGHER

Package contents

With the instrument it is also supplied:

- Quick installation guide.
- Mounting panel accessories (a sealing gasket and 2 fixing clips).
- Wiring accessories (plug-in terminal block connectors and 2 key tools for cable insertion).
- 4 adhesive labels set with engineering units.

General safety considerations

All instructions and guidelines for the installation and manipulation that are present in this manual must be considered to ensure personal safety and to prevent damage to either the instrument or any equipment connected to it.

Safety of any equipment incorporated to this instrument is responsibility of the system installer.

If this electronic indicator is used in a manner not specified by the manufacturer in this manual, the protection provided by the instrument may be impaired.

Symbols identification



WARNING: Potential risk of danger.

Read completely related instructions when this symbol appears in order to know the potential risk and to know how to avoid it.



WARNING: Risk of electric shock.



Instrument protected by double isolation or reinforced isolation.

Maintenance

To guarantee instrument accuracy, it is recommended to checking its compliance according to the technical specifications listed in this manual, performing calibrations regularly in accordance to operation criteria in each application.

Instrument calibration and/or adjustment should be performed only by an accredited laboratory or directly by the manufacturer.

Instrument repairs should only be carried out by the manufacturer or by its authorized partners.

For frontal device cleaning, just wipe it with a damp cloth and neutral soap product. **DO NOT USE SOLVENTS!**

Conformity declaration

EN 61326-1	Electrical equipment for measurement, control and laboratory use (EMC)	
EN 61000-4-2	Electrostatic discharge (ESD) Air discharge 8kV Contact discharge 4kV	Criterion B
EN 61000-4-3	Electromagnetic fields 10 V/m	Criterion A
EN 61000-4-4	Fast transients (burst) Power lines 2 kV Signal lines 1 kV	Criterion B
EN 61000-4-5	Surge 1 kV L to N 2 kV L,N to Earth 1 kV Signal lines to Earth	Criterion B
EN 61000-4-6	RF conducted interference 3 Vrms	Criterion A
EN 61000-4-11	Voltage dips: 0% V during 1 cycle 40% V during 10/12 cycles 70% V during 25/30 cycles Short interruptions: 0% V during 250/300 cycles	Criterion B Criterion C Criterion C Criterion C
CISPR11	Emission limits Class B	
EN 61010-1	Safety requirements for electrical equipment for measurement, control an laboratory use.	
	General safety Overvoltage category II Pollution degree 2 Conductive pollution excluded Isolation type: Enclosure: Double Power/signal: Basic Power/relays: Double Signal/relays: Double	

Device description

All information contained in this manual is valid for **Typ 9186-VX1XX** models.

Typ 9186-VX1XX models are digital indicators fully configurables that allow input type selection in order to be used as needed. Available signal inputs are the following:

LOAD CELL (30mV, 300mV)

The basic instrument consists of a soldered assembly composed of a main board, a display and an input signal circuits. It can also be incorporated, as an option, an extra plug-in 2 SPDT 8A relays circuit output which is isolated from signal input and power supply. This extra circuit has independent connectors that are located on the rear part of the instrument once it is installed.

Specially designed for direct connection to Load Cells, both models have 4 digits, configurable decimal point and 2 **LED's for setpoints status indication, they are easy to scale into desired engineering units, directly by frontal keys** or rear input signal value in teach mode. They also provide a 5V or 10V DC output for sensor excitation.

Typ 9186-VX1XX models are provided with **20mm-high** digits and a maximum range of **-1999 to 9999** which allows a better reading at longer distance. Minus LED sign is integrated in the most significant digit.

They have three frontal keys to interact with internal software and set configuration in order to adapt their function to particular applications. Device programming runs through some independent menus that show short messages to easily identify input type and/or display configuration steps.

If relays output option card is installed, once it is recognised by the instrument, activates its own configuration menu which is only visible under this conditions.

Dimensions and mounting

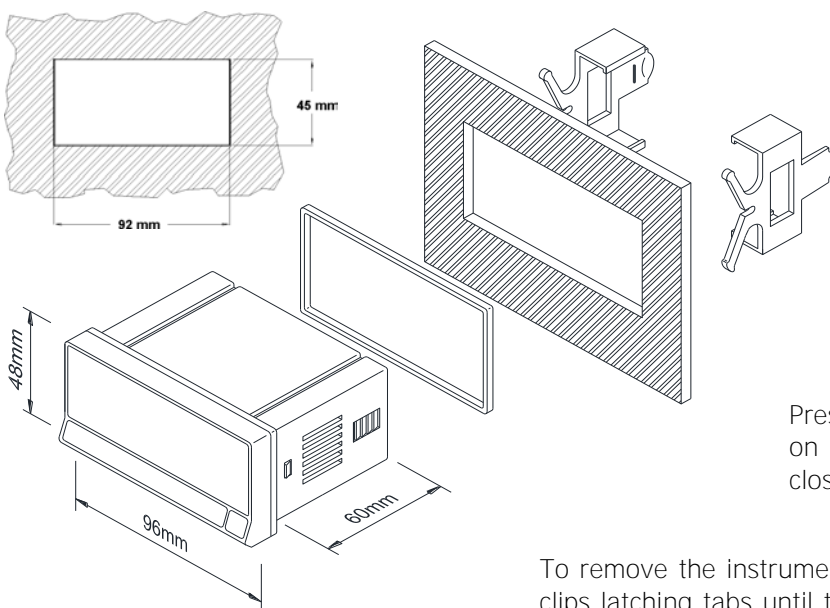

To install the instrument, prepare a 92x45mm panel cut-out and slide the unit inwards making sure of placing the sealing gasket between the front side panel and the frontal bezel.

While holding the unit in place, put the fixing clips on both sides of the case and slide them through the guide tracks until they reach the panel at the rear side.

Press slightly to fasten the clips to the latching slots on the case and get the unit fully assembled and close fitted to achieve a good sealing.

To remove the instrument from the panel, pull outwards the rear fixing clips latching tabs until they are disengaged, then slide fixing clips back over the case.

Display and keyboard

There are two main function modes: **RUN** and **PRO**. **PRO** mode is when configuration menu is entered to programm the indicator, whereas **RUN** is the normal mode in which display shows the reading according to configuration and input signal value.

The table below summarizes display parts description and LEDs and keyboard function.

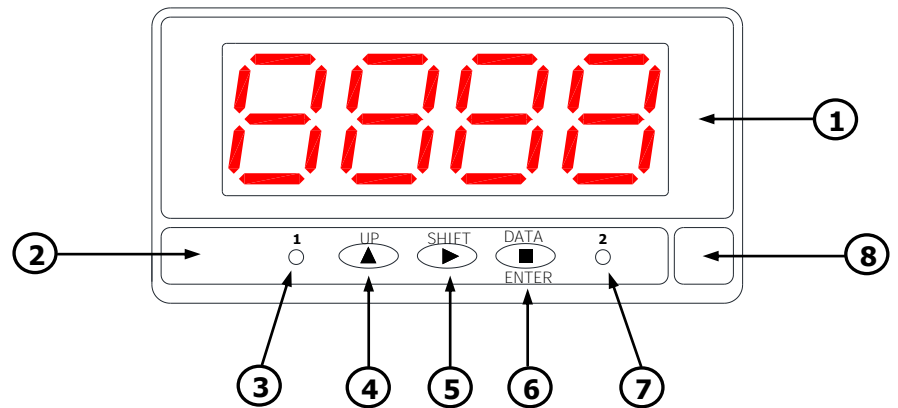

		RUN MODE	PRO MODE
1	4 red digit Display	Shows value according configuration.	Shows steps and data during configuration.
2	Keyboard	—	—
3	Setpoint 1 LED	It iluminates when Setpoint 1 turns active.	It iluminates when Setpoint 1 turns active.
4	UP key	Display TARE. TARE RESET (when pressing more than 3s).	Shows Setpoints value. Increases value of active digit.
5	SHIFT key	Displays maximum and minimum stored values. After 3s of pressing, sets maximum and/or minimum memorized value to current display value.	Shifts active digit to the next right digit. Shows sequentially menu options.
6	DATA/ENTER key	Changes to PRO mode.	Validates selected data and parameters. Moves one step forward in configuration menu. Changes to RUN mode.
7	Setpoint 2 LED	It iluminates when Setpoint 2 turns active.	It iluminates when Setpoint 2 turns active.
8	Free space for units label	—	—

Installing and connecting recommendations

This instrument coforms with the following community directives: EMC 2004/108/CE and LVD 2006/95/CE. Refer to the instructions in this manual to preserve safety protections.



WARNING: If this instrument is not installed and used in accordance with this instructions, the protection provided by it against hazards may be impaired.

To meet the requirements of EN 61010-1 standard, where the unit is permanently connected to main supply, its is obligatory to install a circuit breaking device easy reachable to the operator and clearly marked as the disconnecting device.

To guarantee electromagnetic compatibility, the following guidelines should be kept in mind:

- Power supply wires should be separatedly routed from signal wires and **never runned** in the same conduit.
- Use shielded cable for signal wiring.
- Cables section should be $\geq 0.25 \text{ mm}^2$.

Before connecting signal wires, signal type and input range should be verified to be within the right limits.

Connections

Basic instrument has two rear connectors **CN1** and **CN2**. If 2RE output option card is installed, two more connectors **CN3** and **CN4** appear. See all four connectors location and their pin out in the right figure. All female provided terminal connectors are of CAGE CLAMP® technology.

Terminals for **CN2** connector admit cables with section from **0.2mm² up to 1.5mm² (AWG 24÷14)**.

Terminals for **CN1, CN3** and **CN4** connectors admit cables with section from **0.08mm² up to 2.5mm² (AWG 28÷12)**.

To perform wiring connections, strip the cable leaving from 7 to 10mm exposed to air, insert it in the proper terminal while pushing down the key insertion tool to open the clip inside the connector. Release the key tool to fix wire to the terminal.

Proceed in the same way for the rest of terminals. Once all connections are done, plug connectors to the instrument.

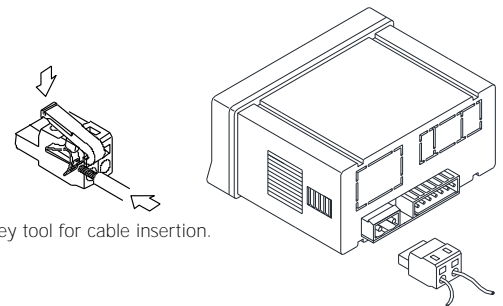
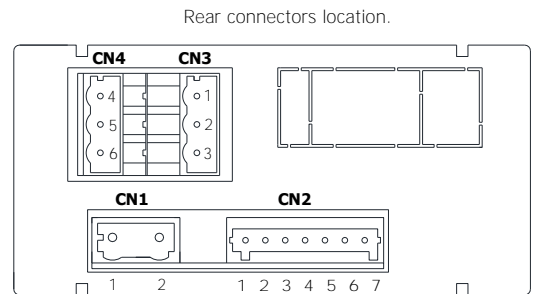

CN4 (relay 2)	
4	NO
5	CM
6	NC

CN3 (relay 1)	
1	NO
2	CM
3	NC

CN1*	
1	Phase (AC)
2	Neutral (AC)

CN2	
1	-IN (COMMON)
2	+IN (300mV / 30mV)
3	N.C.
4	+TARE
5	- EXC / TARE
6	+EXC
7	N.C.

Notes:

NO: Normally open contact.

CM: Common contact.

NC: Normally closed contact.

* Polarity in CN1 is indistinct for DC power.



WARNING

Isolation:

1500Vrms for 1 minute to signal terminals (CN2) and power terminals (CN1).

2500Vrms for 1 minute to signal terminals (CN2) and relays terminals (CN3 y CN4).

2500Vrms for 1 minute to power terminals (CN1) and relays terminals (CN3 y CN4).

Load cell input signal wiring diagrams (mV)

LOAD CELL CONNECTION WITH EXCITATION SUPPLIED BY THE INDICATOR

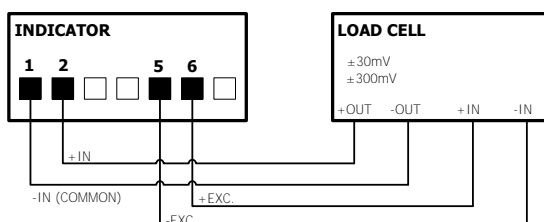

NOTE:

The instrument can supply excitation to multiple load cells connected in parallel as long as 30mA of total load current is not exceeded.

CONNECTION TO A GROUP OF LOAD CELLS WITH EXTERNAL EXCITATION

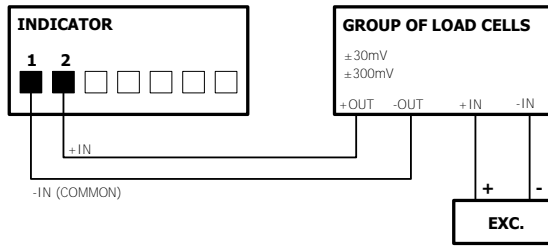

WIRING DETAIL CONNECTION FOR n LOAD CELLS WITH EXTERNAL EXCITATION

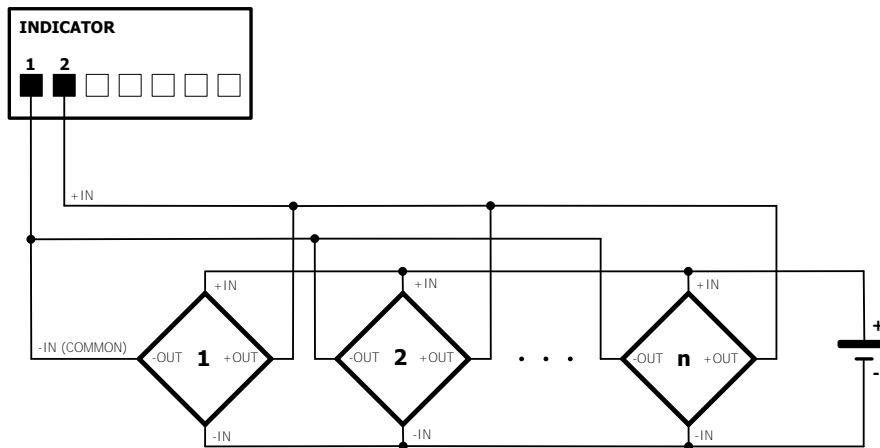

Remote TARE function wiring diagram

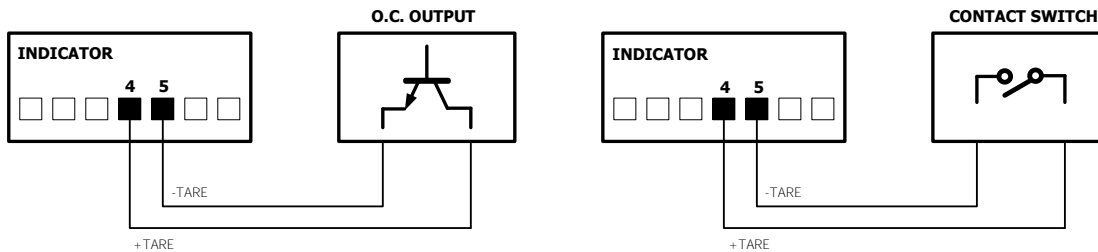

NOTE:

When using an open collector output, the external electronic circuit connected between pin 4 and pin 5 of CN2 input connector, must be able to provide a current of **4mA** and withstand up to **40V**.

In both cases **remote TARE** is activated when contact is closed less than 3 seconds. **Remote TARE RESET** is identically activated through these pins when contact is closed for at least 3 seconds.

Relays output wiring

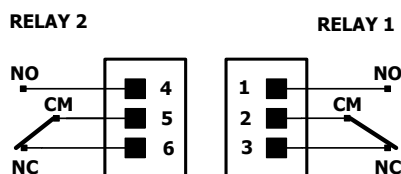

8A/250V MAX.



WARNING:

Read recommendations and related data on pages 7 and 8.

IMPORTANT:

To guarantee electrical safety according to EN 61010-1 a protective **8A/250V** external fuse must be installed.

INPUT CONFIGURATION

Configuration menu



When connecting instrument to Power supply, display test begins automatically to check the good function of LEDs and digits, once this test is finished, display shows internal software version and then the unit goes to **RUN** mode.

Configuration software has a hierarchical structure composed of a number of menus and submenus. By pressing **ENTER** key, display shows "**Pro**", a new pressing brings access to main menu where appear configuration menus, that is, input configuration (**InP**), display configuration (**dSP**) and setpoints configuration (**SEtP**). This last menu only appears if 2RE output option card is installed.

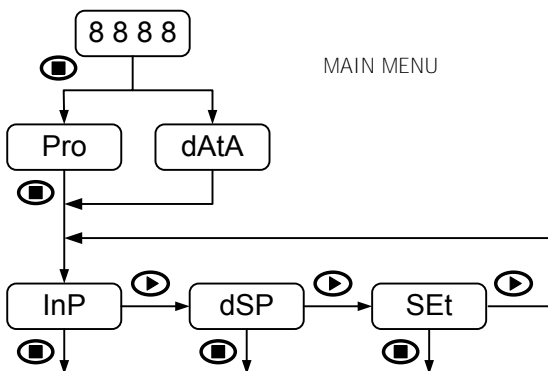
If configuration is totally locked-out, when pressing **ENTER** key to get into main menu, display shows "**dAtA**" instead of "**Pro**". This indicates that it is only possible to see programmed information and that it is not allowed to modify any parameter from the entire configuration. In this visualization mode, the instrument automatically switches back to **RUN** mode after 15 seconds since last key press.



The instrument provides 3 keys for progressing through the menus and submenus and for data introducing/modifying:

-  **ENTER**: Vertical displacement / Validates data.
-  **UP**: Increases active digit value.
-  **SHIFT**: Horizontal displacement / Changes active digit.

Once inside each menu, all configuration parameters are sequentially shown and they can then be introduced or edited by pressing **ENTER** key. Numeric values must be entered digit by digit, first selecting digit and then changing its value. When the display reach desired value, a new **ENTER** key pressing validates data and routine goes forward to next configuration step.

Data entered or changes made during configuration are stored in device memory only when programming routine belonging to the respective submenu is completed, not before. On last routine step and after having pressed **ENTER** key, display indicates "**Store**" and the unit goes back again to **RUN** mode.

Input configuration

The first menu corresponds to input configuration. This, in turn, consists of two options, one for each input type: (**300**) and (**30**).

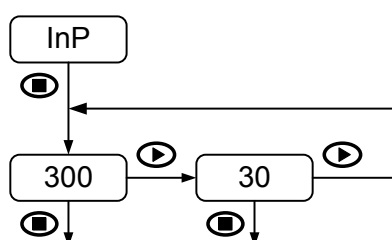

No additional configuration is needed for these input types (direct validation).

SIGNAL TYPE:

- 300**: Input signal up to **±300mV DC**
- 30**: Input signal up to **±30mV DC**

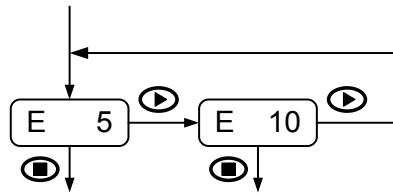

EXCITATION LEVEL:

Configurable value:

E 5: 5V DC

E 10: 10V DC

Once input range is selected, the routine goes to configure excitation. 5V and 10V are available. In both cases load current limit is **30mA DC**.

DISPLAY CONFIGURATION

Display Programming

The second menu corresponds to display configuration. This, in turn, consists of some submenús: through frontal keys configuration (**SCAL**), through real input signal (TEACH) (**tEAC**) and reading stabilization filter (**FiLt**).

THROUGH FRONTAL KEYS CONFIGURATION "SCAL"

Input and display values are configured **manually through the three keys** of the instrument. This method is suitable when signal values supplied by the transducer at each extreme point of the process are known.

REAL INPUT SIGNAL CONFIGURATION "tEAC"

Input values are **directly introduced from CN2 input connector just at the moment of signal capturing at each point of the process**. Display values are configured manually through the three keys, as in the previous case. This method is suitable when signal values at each point are unknown but, it is possible to lead process to the conditions defined by these extreme points.

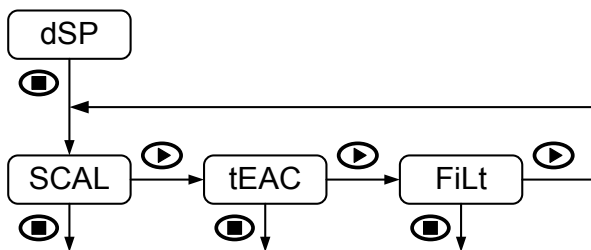

WEIGHTED AVERAGE FILTER "FiLt"

Sets low-pass filter cutoff frequency (F_c) which allows the instrument to smooth out undesirable display reading fluctuations.

Display scaling

Display scaling is necessary when adapting display reading to a particular engineering unit. Display range can be configured between **-1999** and **9999**.

Display scaling is a linear process that consists in introducing two input values, referred as **Input 1** and **Input 2**, and their respective display values, referred as **Display 1** and **Display 2**. On the basis of this proportional relationship internal software calculates display value that would correspond to a given input value. Decimal point position would complete required engineering units indication.

It is possible to scale display in an increasing or decreasing proportional mode depending on whether if second display value (**DISP.2**) is greater or less than the first (**DISP.1**). In an increasing mode, display value increases proportionally to the input value whereas in a decreasing mode, display value decreases. The left figure below shows both scaling modes.

IMPORTANT IN "tEAC" MODE:

To ensure the best accuracy, both points 1 and 2 should represent extreme process limits.

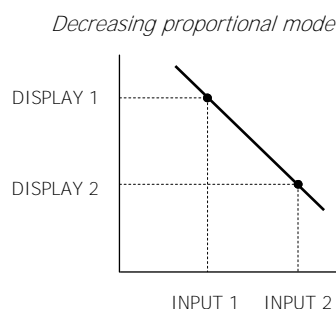
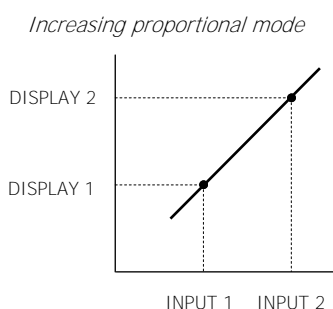

The right figure shows an example for a 150kg and 2mV/V load cell with a 10V DC excitation. Decimal point is situated between third and fourth digit of the display.

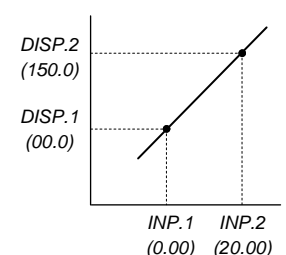

mV input

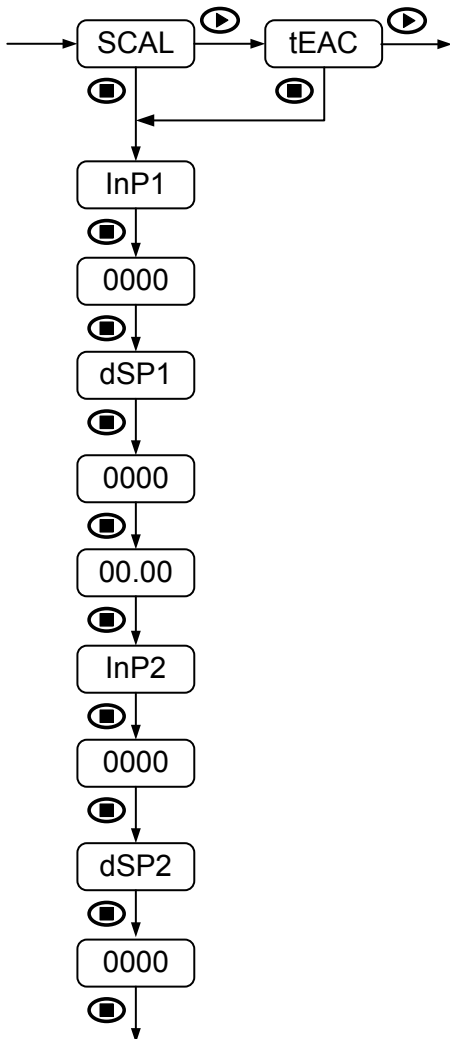

For both display scaling "SCAL" and "tEAC" methods, parameters to be sequentially introduced are identical.

It only must be considered that in "SCAL" method, all values must be manually introduced through the three frontal keys whereas in "tEAC" method, input signal value must be present at the connector at each point that is intended to be configured.

FIRST POINT INPUT AND DISPLAY VALUE:

- InP1:** Input value indication.
- 0000:** Value entering in counts within available model display range.
- dSP1:** Display value indication.
- 0000:** Value entering in counts within available model display range.

DECIMAL POINT:

- 00.00:** Setting of decimal point position.
(Decimal point can be located in any position, and will be the same for Display 1 and Display 2. This position remains fixed for all configuration steps and also for **RUN** mode).

SECOND POINT INPUT AND DISPLAY VALUE:

- InP2:** Input value indication.
- 0000:** Value entering in counts within available model display range.
- dSP2:** Display value indication.
- 0000:** Value entering in counts within available model display range.

NOTE:

Display configuration/scaling is independent to stored TARA value present in memory. It only must be considered that, once this configuration is finished, display reading will be affected by that TARE value.

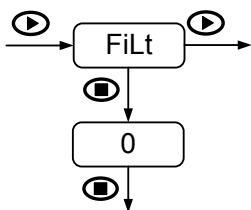

WEIGHTED AVERAGE FILTER:

FiLt: 0 to 8 Configurable



Value	Fc (Hz)	Value	Fc (Hz)
0	--	5	0.35
1	1.20	6	0.29
2	0.44	7	0.23
3	0.41	8	0.18
4	0.38		

SETPOINTS CONFIGURATION

Setpoints configuration

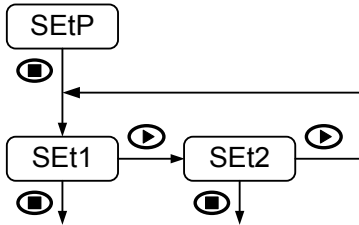

The third menu "SEtP" only appears when two relays output card is installed. For further details on function modes please refer to the corresponding **OUTPUT OPTION** part later on this manual.

Programming steps are equal for both relays on each "SEt1" and "SEt2" submenus. The parameters to be configured are the following:

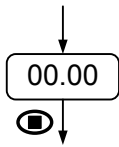

SETPOINT VALUE:

00.00: Value entering in counts within available model display range.
(Is not possible to change decimal point position, which is the previously defined in display configuration menu).

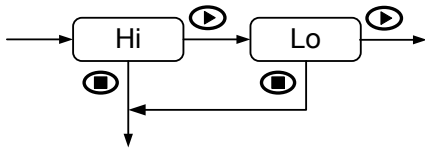

ACTIVATING MODE:

Hi: High level relay activation.
Lo: Low level relay activation.

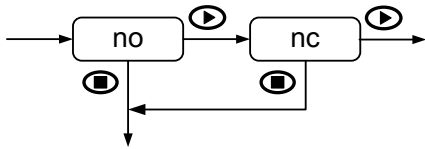

RESTING CONTACTS STATE:

no: Normally open contact.
nc: Normally closed contact.

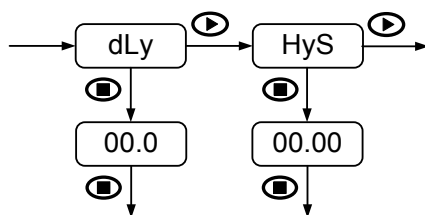

TIME DELAY AND HYSTERESIS:

dLy: Programmable delay from **0** to **99.9s**.
HyS: Hysteresis in counts within available model display range.

If 2RE output option card is uninstalled, the instrument keeps setpoints last configuration in memory, though it can not be visualized.

Thanks to this feature there will be no need to reconfigure relays setting when 2RE output option is again installed if the same configuration is required.

AVAILABLE KEYBOARD FUNCTIONS

In addition to already known functions used to browse through the configuration menus and submenus, introduce and/or modify existing values and parameters, the instrument provides some more added functions.

TARE, MAX/MIN and RESET functions

TARE function activates by pressing **UP** key (or by closing contact between pin 4 and pin 5 from CN2 input connector, see page 9). Current display value is then stored (or added) in memory and the instrument shows (by default) "0.00" or "0.0", depending on whether configured input range is 30mV or 300mV respectively. At the same time, after the first digit (from the right), a point starts flashing indicating that the instrument has stored a TARE value.

It is possible to tare instrument as many times as needed, as long as the accumulated value does not exceed the limit value defined by the working range. Otherwise overflow indication "OuE" will be displayed. Stored tare value remains in memory although power supply is removed.

This device detects and stores in memory maximum and minimum values reached by the input signal. This values remain in memory although power supply is removed, as well. When pressing repeatedly **SHIFT** key, **MAX/MIN** function shows saved maximum and minimum values in display since last **RESET** function activation.

In order to differentiate this values indication from a mode **RUN** indication, decimal point blinks during the time these values are shown. The unit automatically switches back to **RUN** mode after 15 seconds have elapsed since the last key press.

First **SHIFT** key pressing shows "MAH" in display followed by the maximum value, a second pressing now shows "Min" followed by the minimum value and finally, a third pressing shows "run" to back again in an instant to **RUN** mode.

MAX/MIN RESET function activates when visualizing maximum or minimum values **SHIFT** key is pressed for at least 3 seconds. If maximum is the displayed value, current input signal value will replace the previous maximum saved value. In the same way, current input signal will replace saved minimum value while is the minimum the displayed value. It is also activated by a **TARE** or **TARE RESET** functions.

TARE RESET function activates by pressing **UP** key or maintaining remote contact closed for at least 3 seconds. This is only possible in **RUN** mode. After that time, stored value will be added to the current display and erased from memory and the flashing point will disappear.

Direct access to setpoints value

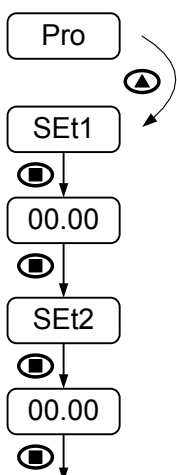

If 2RE output option is installed, it is possible to access to setpoints value configuration without having to enter main menu.

To access this submenu, from **RUN** mode and after **ENTER** key is pressed, simply press **UP** key while "Pro" is displayed.

FIRST SETPOINT VALUE:

Set1: Setpoint 1 value indication.

00.00: Value entering in counts within available model display range.

SECOND SETPOINT VALUE:

Set2: Setpoint 2 value indication.

00.00: Value entering in counts within available model display range.

Return to default configuration

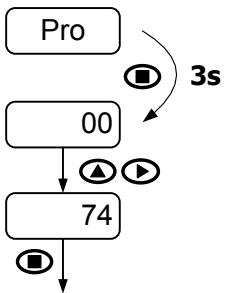

To access this menu from **RUN** mode, press **ENTER** key and while display shows "**Pro**" press again **ENTER** for at least 3 seconds.

Display shows now "**00**" and '**74**' code must be introduced through **SHIFT** and **UP** keys.

Finally press **ENTER** to validate configuration and back to **RUN** mode.

Access to lock-out configuration menu

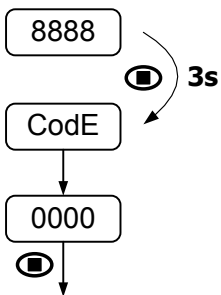

To access this menu from **RUN** mode, press **ENTER** key for at least 3 seconds.

Display shows now "**CodE**" and then "**0000**". Desired security code must be introduced through **SHIFT** and **UP** keys (by default this code is **0000**).

Finally press **ENTER** to begin with lock-out level configuration. If entered security code is wrong, the instrument will go back to **RUN** mode.

CONFIGURATION LOCK-OUT

Lock-out menu

In order to prevent accidental or undesirable modifications of instrument parameters, a selective or total configuration lock-out is available. By default the unit is delivered unlocked, giving access to all programming levels. Once in this menu, the first option will be to choose between lock-out level setting ("LiSt") or security access code changing ("CHAn").

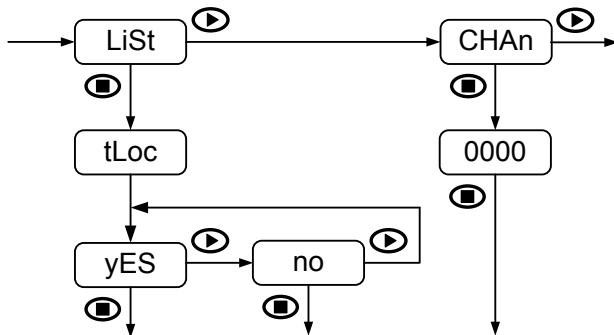

If "LiSt" option is selected, display will show momentarily "tLoc". Total configuration lock-out is activated by selecting "yES", then routine directly jumps to TARE function and SHIFT key for MAX/MIN function lock-out configuration before the unit goes back to **RUN** mode. **When total lock-out is set, no data can be entered or modified**, although it will still be possible to visualize all programmed parameters. Under these conditions when entering main menu, initial indication will be "dAtA" instead of "Pro".

On the other hand, when "no" option is selected, routine move on to next step to configure a partial lock-out. **When a partial lock-out is set, only non-locked data can be entered or modified**. Under these conditions when entering main menu, initial indication will be "Pro".

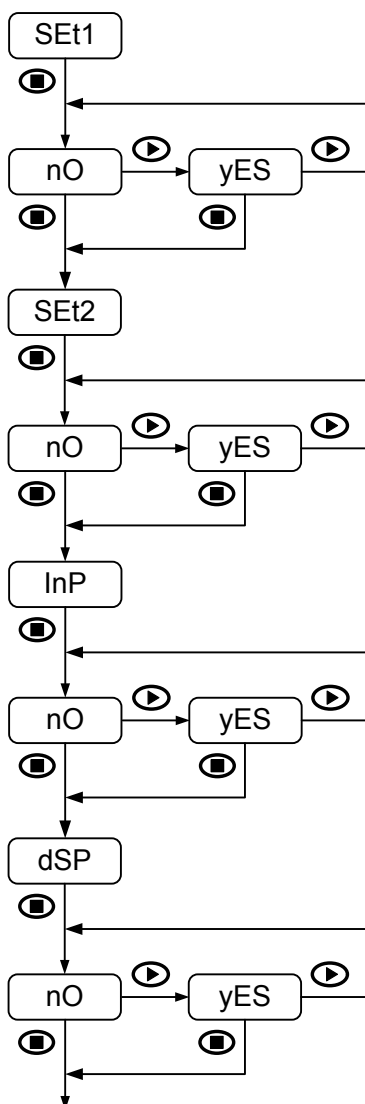

The following configuration access can be locked-out:

- Setpoint 1 configuration (**SEt1**)
- Setpoint 2 configuration (**SEt2**)
- Input configuration (**InP**)
- Display configuration (**dSP**)
- TARE function configuration (**tArE**)
- SHIFT key configuration for MAX/MIN function (**MAH**)

In each case lock-out is activated by selecting "yES" option and deactivated by selecting "no".

Setpoints 1 and 2 configuration lock-out is available only when 2RE output is installed.

If 2RE output option card is uninstalled, the instrument keeps setpoints last configuration in memory, though it can not be visualized. There will be no need to reconfigure setpoints lock-out when 2RE output option is again installed if the same configuration is required.

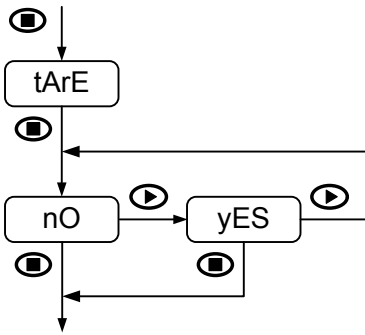

Access to TARE and TARE RESET functions activated through UP key can be blocked, as well.

NOTE:

Remote TARE and remote TARE RESET lock-out through pin 4 and pin 5 from CN2 is not available. These functions remain always active.

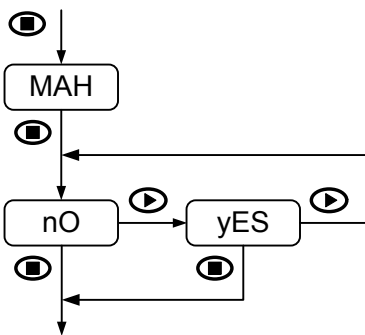

SHIFT key lock-out for MAX/MIN function is configurable in the same way as previous configurations.

When lock-out is enabled (selecting "yES") it is not possible to visualize maximum or minimum values by pressing SHIFT key, although instrument internally continues detecting and saving new extreme values reached by input signal.

Once the instrument programming is completed, if there are parameters that are going to be frequently changed, a partial lock-out is recommended. A total lock-out is recommended when configuration parameters will be constant for a long time.

Changing default security code and keep new one in a safe place is also strongly recommended.

OUTPUT OPTION

Description

2RE output option allows TYP 9186-VX1XX models to perform control operations and limit values treatment via two ON/OFF logic outputs. It is supplied as an independent card that is connected to main board without any additional operation since internal software recognizes it once it is installed. There is no need to read the manual since all information required is contained in this user manual.

Function modes description

Alarms are independent, they become activate when display value reach setpoint level programmed by the user. For a correct configuration it will be necessary to define function mode, as well.

HI/LO mode activation

In **HI** mode, output activates when display value goes above setpoint level, whereas in **LO** mode, output activates when display value falls below setpoint level.

Time delay

Both output actions can be deferred by a configurable time delay from 0 up to 99.9 seconds.

Time delay activation starts when display value reach each setpoint '**SET**' in either increasing or decreasing mode, obtaining the '**dly**' delay in output activation/deactivation as right figure shows.

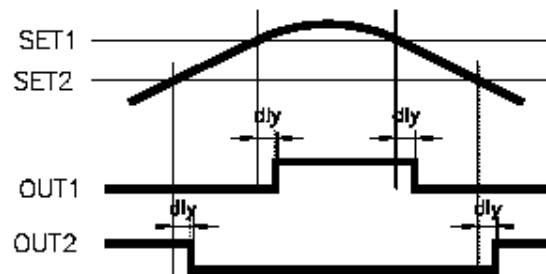

Time delay for OUT1 (**HI** mode) and for OUT2 (**LO** mode)

Asymmetrical hysteresis

Both output actions can be deferred by a hysteresis level which is configurable in counts within full available display. Decimal point position is the previously defined in display configuration menu.

Asymmetrical hysteresis action only starts in the output deactivation edge, obtaining as a result the '**hys-1**' delay as indicated on the right figure.

Note that outputs activation is not affected by hysteresis and they activate in each case just when setpoint '**SET**' is reached by display.

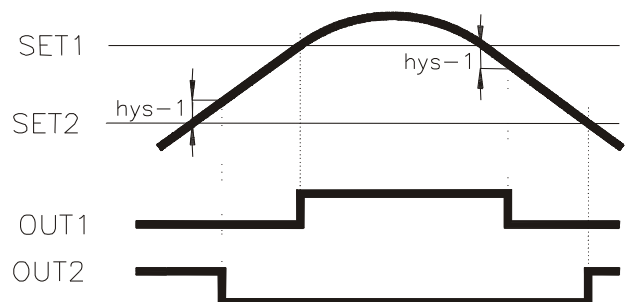

Hysteresis delay for OUT1 (**HI** mode) and for OUT2 (**LO** mode)

Installation

To physically install the output option, the electronics assembly should be first lifted out from the case. Use a screwdriver or similar to slightly press both side tabs until the rear case is released. Then broke the junctions from the corresponding polycarbonate cover in order to obtain the required orifice in the case. This orifice will allow 2RE connectors come out through instrument rear part once it is installed.

Install 2RE option on the indicated location pushing slightly down until both connectors get perfectly together. For best installation, it is recommended to solder this card to the main circuit making use of the copper pads on both sides of its insertion pin and those surrounding the circuit hole where it is inserted in.

Once 2RE is installed, carefully put the circuitry again inside the case verifying that circuits slide properly without much effort through rear case internal guides.

Each output card is supplied with an adhesive label that indicates wiring connections. To help identifying terminals, this label should be placed in the upper side of the unit case. Besides its own connections, there are other output options indications for other outputs that can be installed in other model indicators.

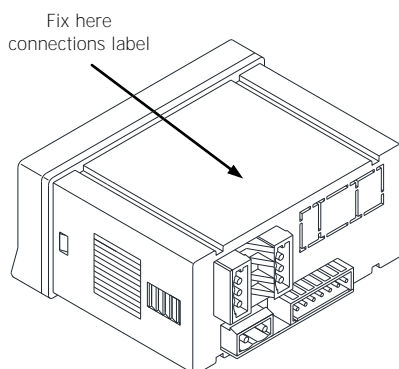
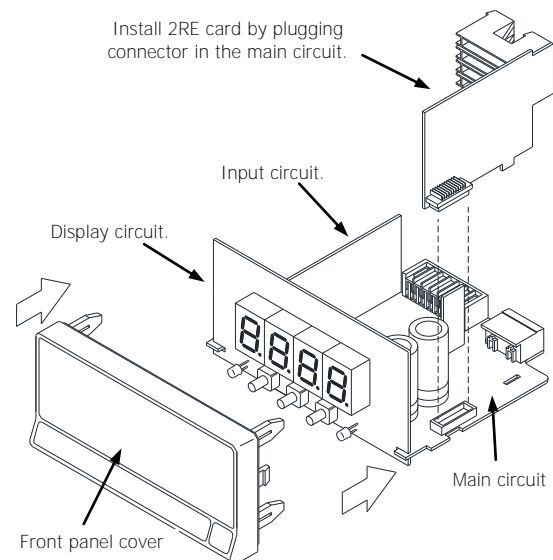
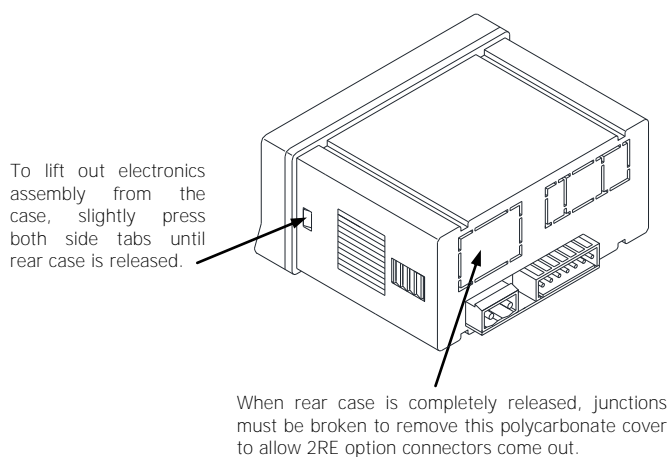

Once 2RE is installed and instrument is again inside the case, 2RE connectors should come out through the obtained orifice as this figure shows.



WARNING:

Disconnect all power and rest of input signals connected to the indicator before installing or extracting the output option card.

DESK VERSION OPTION 9186-V31XX

Connectors location and description

8 pin assignment for terminal implementation

Pin	
1:	GND reference
2:	TARE (DMS)
	Digital Out function
3:	NO1
4:	COM1
5:	NC1
6:	NO2
7:	COM2
8:	NC2

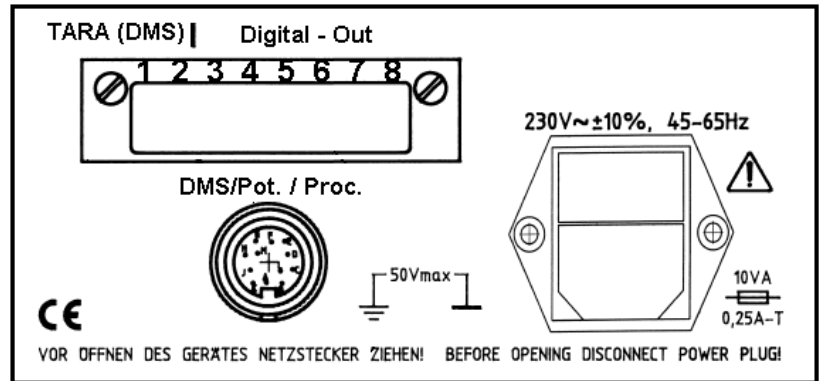

9186-V31XX with Load Cell (DMS) wiring diagram

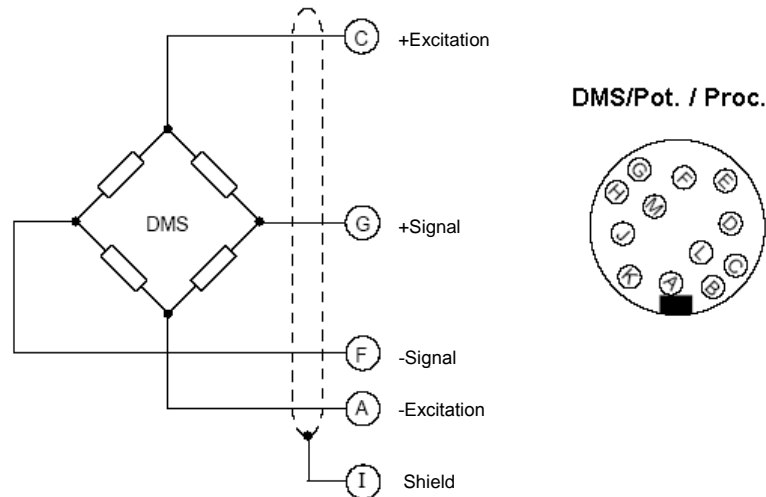

SPECIFICATIONS

Technical specifications

SPECIAL FUNCTIONS

Return to factory configuration.
Software configuration lock-out.

PRECISION

Temperature coefficient 100 ppm/°C
Warm-up time 5 minutes
Specifications range 23°C±5°C

POWER SUPPLY AND FUSES (DIN 41661) (not included)

Typ 9186-VX1XX:

20-265 V AC 50/60 Hz and 11-265 V DC F 3A/ 250V
Power consumption 3W
Sensor excitation (stabilized) 5V or 10V DC
Maximum load current 30mA

CONVERSION

Technique Sigma-Delta
Resolution 16 bit
Conversion rate 20/s

DISPLAY

Range:
Typ 9186-VX1XX -1999 ÷ 9999, 20mm RED LED
Decimal point Configurable
LEDs 2 for setpoints state indication
Display refresh rate 50ms
Display/input overrange indication "-OuE", "OuE"
Sensor failure indication "OuE"
TARE and TARE RESET functions Through frontal key
Remote TARE function Logic input (O.C.) or contact switch
Remote TARE RESET Logic input (O.C.) or contact switch
MAX./MIN. and MAX./MIN. RESET func. Through frontal key

ENVIRONMENTAL CONDITIONS

Operating temperature -10°C ÷ +60°C
Storage temperature -25°C ÷ +85°C
Relative humidity (non-condensing) <95% @ 40°C
Maximum altitude 2000m
Frontal protection degree IP65

INPUT SIGNAL

Configuration Differential asymmetrical

mV DC input

Input impedance 3MΩ
EMI max. Influence (±30mV) ±6μV
EMI max. Influence (±300mV) ±60μV
Maximum input signal (±30mV) ±32mV
Maximum input signal (±300mV) ±320mV

RANGE	RESOLUTION	ACCURACY
±30mV	1μV	±(0.05%rdg + 6μV)
±300mV	15μV	±(0.05%rdg + 60μV)

FILTER

Cutoff frequency (-3dB) 1.20Hz to 0.18Hz
Slope -20dB/Dec.

DIMENSIONS

Dimensions 96 x 48 x 60 mm (1/8 DIN).
Panel cutout 92 x 45 mm.
Weight 150g.
Case material UL 94 V-0 polycarbonate.

2RE OPTION

Maximum switching current (resistive load) 8A
Maximum switching power 2000VA / 192W
Maximum switching voltage 400VAC / 125VDC
Contact rating 8A @ 250VAC / 24VDC
Contact resistance ≤ 100mΩ at 6V DC @ 1A
Contact type SPDT
Operate time ≤ 10ms

NOTE:

In case that the outputs are used to drive inductive loads, it is recommended to add an RC network between the coil terminals (preferably) or between the relay contacts, to limit electromagnetic effects and to extend contacts life.

NOTES:

INSTRUMENT CONFIGURATION

Use the following template for the annotation of configured parameters in your instrument for later consulting or data recover.

INPUT:

TYPE:
RANGE:

DISPLAY:

CONFIG. MODE: SCAL TEACH
INPUT 1:
DISPLAY 1:
INPUT 2:
DISPLAY 2:
FILTER (0 ÷ 8):

SETPOINTS:

SET1:
MODE: no nc
DLY:
HYS:
SET2:
MODE: no nc
DLY:
HYS:

LOCK-OUT:

ACCESS CODE:



burster präzisionsmesstechnik gmbh & co kg
Talstr. 1-5 D-76593 Gernsbach
Germany

Tel. +49 07224-6450
Fax +49 07224-64588
Email: info@burster.de ; web: www.burster.de